

Service Manual

HONEYCOMB DISC SPEAKER SYSTEM

SB-7
(XG), (XGE)

SB-7K
(XG), (XA), (XGB),
(XGF)

SB-10K
(XG), (XGB), (XGE),
(XGF), (XA)



* The models SB-7K (XA) and SB-10K (XA) are available in Asia, Latin America, Middle East and Africa only.

* The models SB-7 (XG), SB-7K (XG) and SB-10K (XG) are available in European only.

* The models SB-7K (XGB) and SB-10K (XGB) are available in Belugum only.

* The models SB-7 (XGE) and SB-10K (XGE) are available in United Kingdom only.

* The models SB-7K (XGF) and SB-10K (XGF) are available in France only.

SB-7/K

■ SPECIFICATIONS

(Specifications are subject to change without notice.)

Type: 3 way 3 speaker system
Speakers: Woofer: 25 cm honeycomb disc
 Midrange: 8 cm honeycomb disc
 Tweeter: Leaf Tweeter (fullsurface-movement type)
Impedance: 8 ohms
Input Power: 130 W Music
 90 W DIN

Output Sound Pressure Level: 87 dB/W (1.0 m)
Crossover Frequency: 900 Hz, 4500 Hz
Frequency Range: 34 Hz ~ 125 kHz (-10dB)
Dimensione: 36.0(W) x 63.0(H) x 31.8(D) cm
Weight: 19.0 kg

■ TECHNISCHE DATEN

(Änderungen der technischen Daten vorbehalten)

Typ: 3 Weg-System mit 3 Lautsprechern
Lautsprecher: Tieftonlautsprecher: 25 cm
 Wabenscheibe
 Mitteltonlautsprecher: 8 cm
 Wabenscheibe
 Hochtonlautsprecher: Blattlautsprecher. (Mit vollschwingen der Oberfläche)
Impedanz: 8 Ohm
Belastbarkeit: 130 Watt Musik
 90 Watt DIN
Abgegebener Schalldruckpegel: 87 dB/W (in 1.0 m Abstand)
Überschneidungsfrequenz: 900 Hz, 4500 Hz
Frequenzbereich: 34 Hz ~ 125 kHz (-10 dB)
Abmessungen: 36.0(B) x 63.0(H) x 31.8(T) cm
Gewicht: 19.0 kg

■ SPECIFICATIONS

(Les sésifications sont susceptibles detre modifiées préavis)

Type: 3 voies, 3 haut-parleurs
Haut-parleurs: graves: 25 cm disque alvéolé
 moyennes: 8 cm disque alvéolé
 aigus: haut-parleur des aigus á feu illes (du type á mouvement de surface dotale)
Impédance: 8 ohms
Entrée maximale: 130 Watts, musique
 90 Watts, DIN
Niveau de pression sonore de sortie: 87 dB/W (1.0 m)
Fréquence de commutation: 900 Hz, 4500 Hz
Gamme de fréquences: 34 Hz ~ 125 kHz (-10 dB)
Dimensions: 36.0(I) x 63.0(H) x 31.8(P) cm
Poids: 19.0 kg

SB-10/K

■ SPECIFICATIONS

(Specifications are subject to change without notice.)

Type:	3 way 3 speaker system	Output Sound Pressure Level:	87 dB/W (1.0 m)
Speakers:	Woofer: 32 cm honeycomb disc Midrange: 8 cm honeycomb disc Tweeter: Leaf Tweeter (fullsurface-movement type)	Crossover Frequency:	400 Hz, 4000 Hz
Impedance:	8 ohms	Frequency Range:	28 Hz ~ 125 kHz (-10dB)
Input Power:	150 W, Music 100 W, DIN	Dimensione:	40.2(W) x 71.1(H) x 31.8(D) cm
		Weight	32.0 kg

■ TECHNISCHE DATEN

(Änderungen der technischen Daten vorbehalten)

Typ:	3Weg-System mit 3 Lautsprechern
Lautsprecher:	Tieftonlautsprecher: 32 cm Wabenscheibe Mitteltonlautsprecher: 8 cm Wabenscheibe Hochtonlautsprecher: Blattlautsprecher. (Mit vollschwingen der Oberfläche)
Impedanz:	8 Ohm
Belastbarkeit:	150 Watt Musik 100 Watt DIN
Abgegebener Schalldruckpegel:	87 dB/W (in 1.0 m Abstand)
Überschneidungsfrequenz:	400 Hz, 4000 Hz
Frequenzbereich:	28 Hz ~ 125 kHz (-10 dB)
Abmessungen:	40.2(B) x 71.1(H) x 31.8(T) cm
Gewicht:	32.0 kg

■ SPECIFICATIONS

(Les spécifications sont susceptibles d'être modifiées préavis)

Type:	3 voies, 3 haut-parleurs
Haut-parleurs:	graves: 32 cm disque alvéolé moyennes: 8 cm disque alvéolé aigus: haut-parleur des aigus à feu illes (du type à mouvement de surface dotale)
Impédance:	8 ohms
Entrée maximale:	150 Watts, musique 100 Watts, DIN
Niveau de pression sonore de sortie:	87 dB/W (1.0 m)
Fréquence de commutation:	400 Hz, 4000 Hz
Gamme de fréquences:	28 Hz ~ 125 kHz (-10 dB)
Dimensions:	40.2(I) x 71.1.(H) x 31.8(P) cm
Poids:	32.0 kg

■ SPEAKER-PROTECTION CIRCUITRY

This unit includes built-in speaker-protection circuitry to protect the tweeter, midrange and woofer from damage by excessive input or an abnormal signal.

- If excessive input is supplied to the speakers, the overload indicator on the front panel of this unit will begin to flash. If the input is further increased, the indicator will flash more quickly and the input will be shut off by the built-in protection circuitry.
- To operate the speaker protection circuitry, please **note the following instructions:**
 1. **Before making connection to the amplifier**, be sure to **push the reset buttons** on the front panel of the enclosure.
 2. **If sounds from the speaker system are interrupted or changed suddenly while using your speaker system:**
 1. **Reduce the amplifier volume.**
 2. **Check to be sure all equipment in your reproduction system is functioning properly.**
 3. **Wait for about 20 seconds.**
 4. **Push the reset buttons.**
 5. If the overload indicator starts to flash more quickly, or after the protection circuitry has functioned, be careful not to increase the volume of the amplifier too much.

■ LEVEL CONTROLS

This speaker system includes level controls which can be used for continuous adjustment of the level of the midrange and tweeter sound depending upon the room acoustics, the sound source, and the characteristics of the phono cartridge and the amplifier which are used with this speaker system, as well as your own preference. The standard setting of the level controls is the "normal" position.

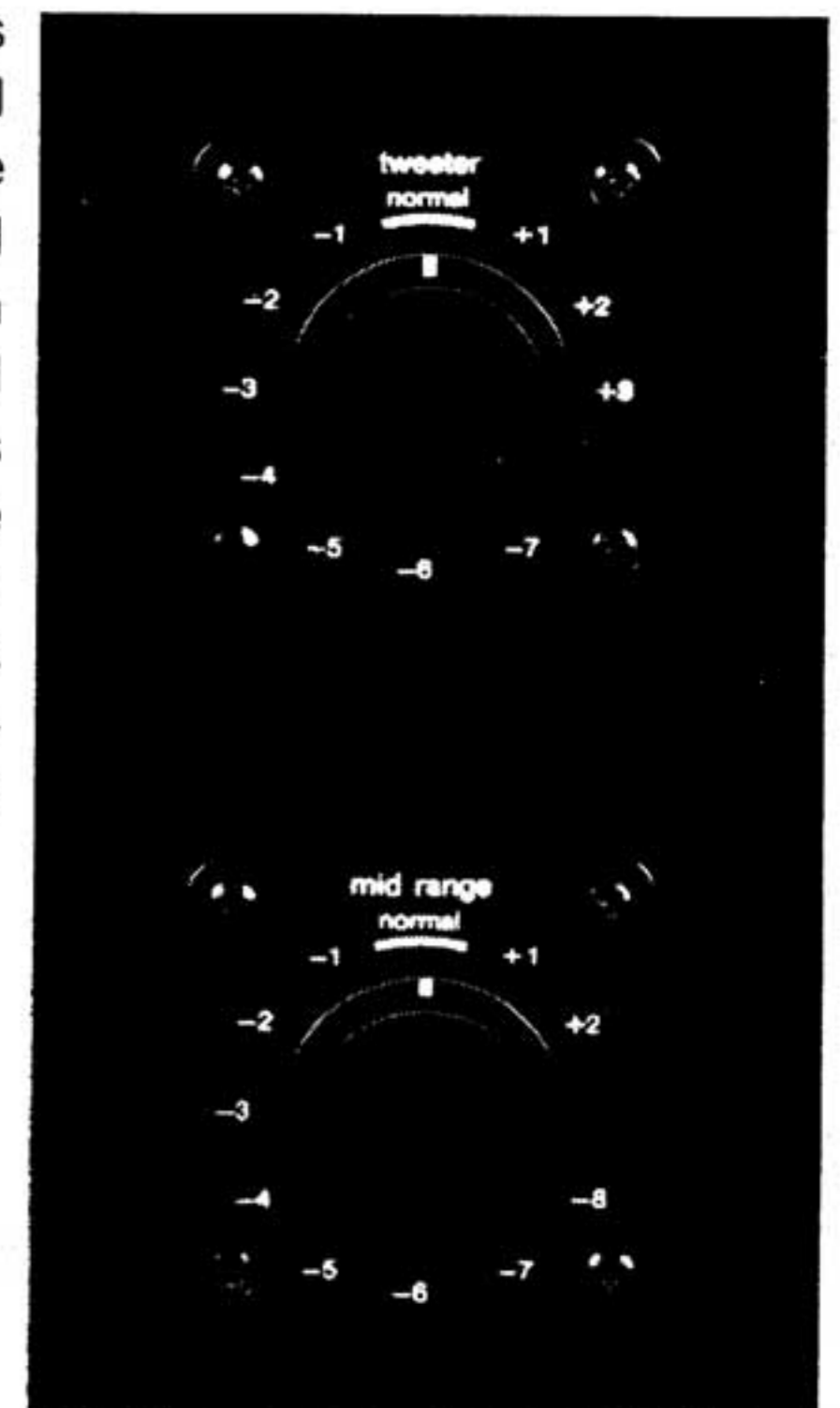

■ SCHEMATIC DIAGRAM (The schematic diagram may be modified at any time with the development of new technology.)

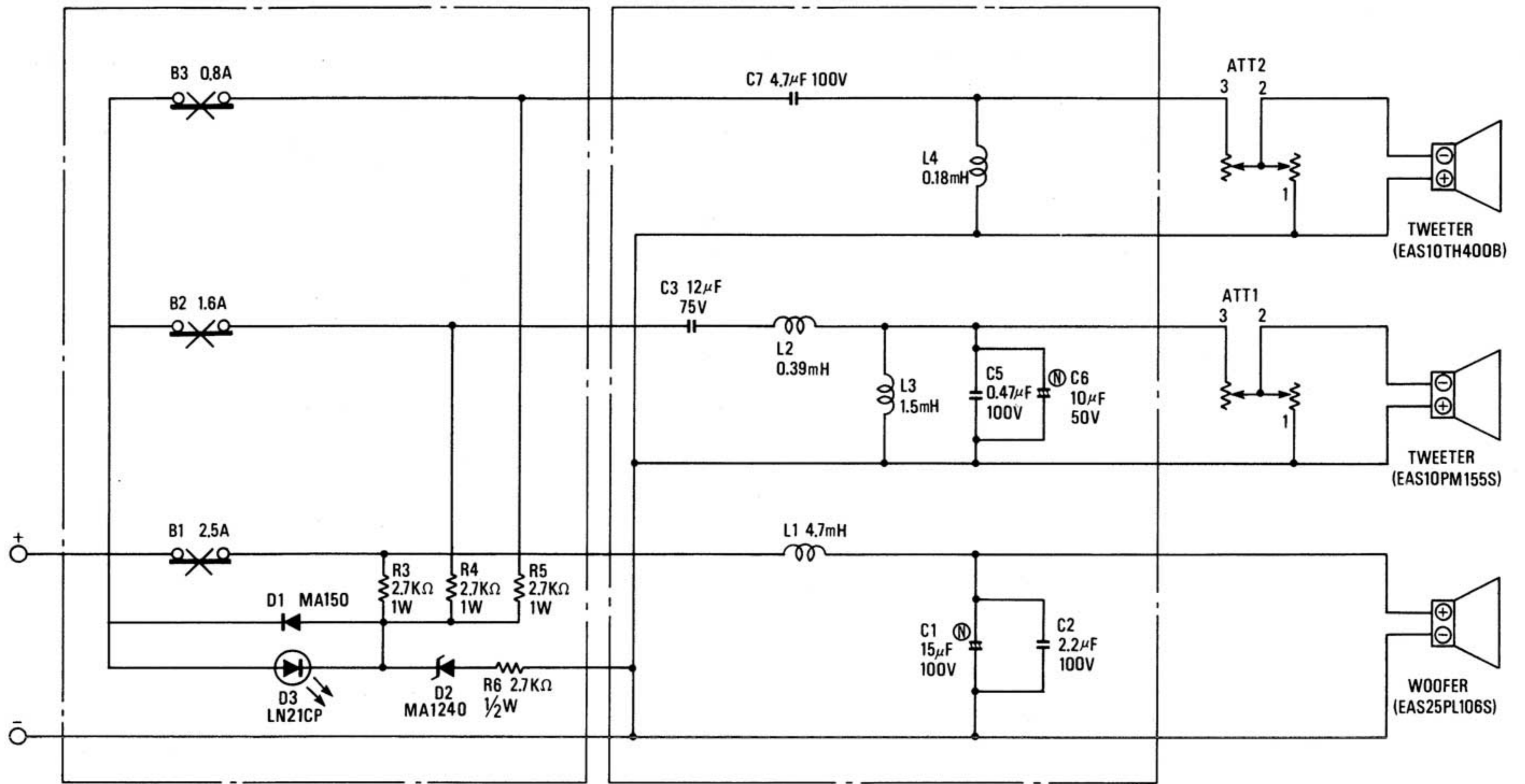

■ CIRCUIT BOARD

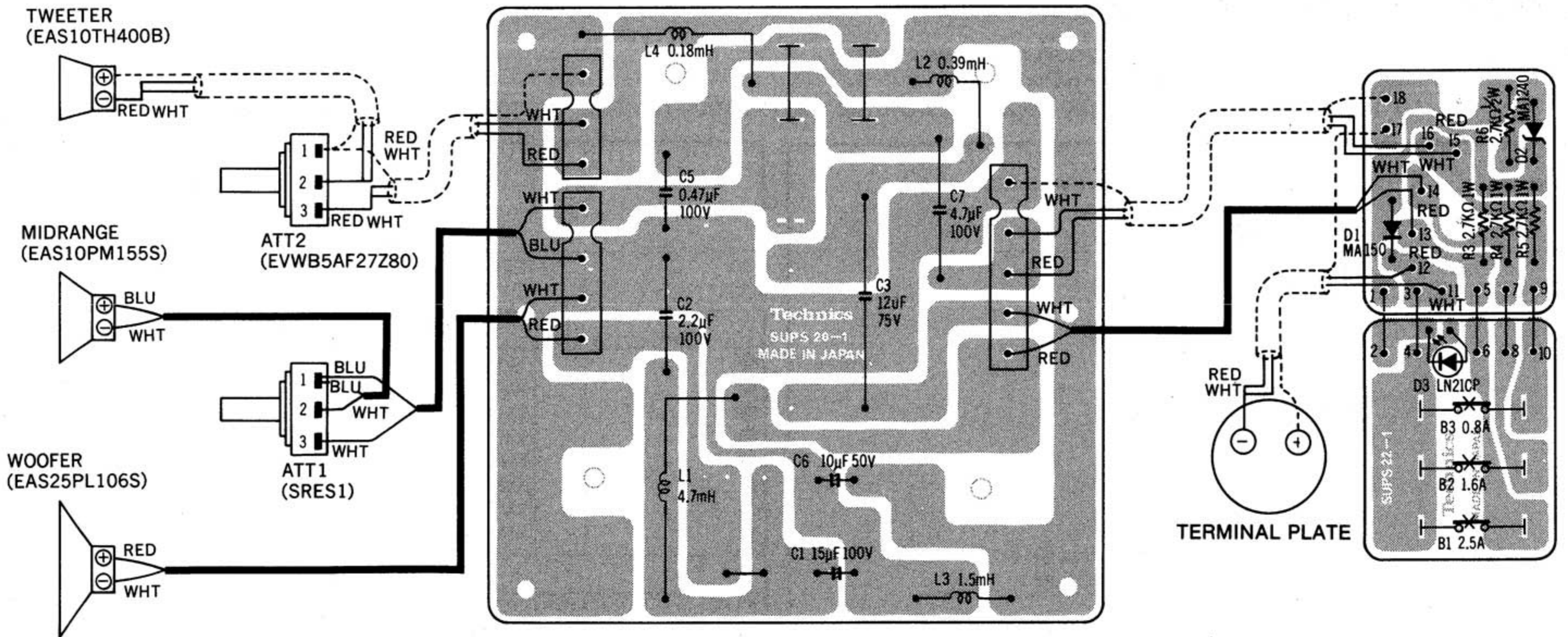

Ref. No.	Part No.
SPEAKERS	
SP1	EAS10TH400B
SP2	EAS10PM155S
SP3	EAS25PL106S
DIODES	
D1	MA162A
D2	SVDMZ324
D3	LN21CP
RESISTORS	
R3, 4, 5	ERG1ANJ272
R6	ERD50FJ272

Ref. No.	Part No.
CAPACITORS	
C1	ECEA100Y15K
C2	ECQE1225KZ
C3	ECQE07126KZ
C5	ECQE1474KZ
C6	ECEA50Y10K
C7	ECQE1475KZ
COILS	
L1	SLCSA472JU
L2	SLCSA391KU
L3	SLCSA152JU
L4	SLCSA181KU

Ref. No.	Part No.
ATTENUATORS	
ATT1	SRES1
ATT2	EVWB5AF27Z80
BREAKERS	
B1	SSB25AB01-1
B2	SSB16AB01-1
B3	SSB08AB01-1

SB-10/K

■ SCHEMATIC DIAGRAM (The schematic diagram may be modified at any time with the development of new technology.)

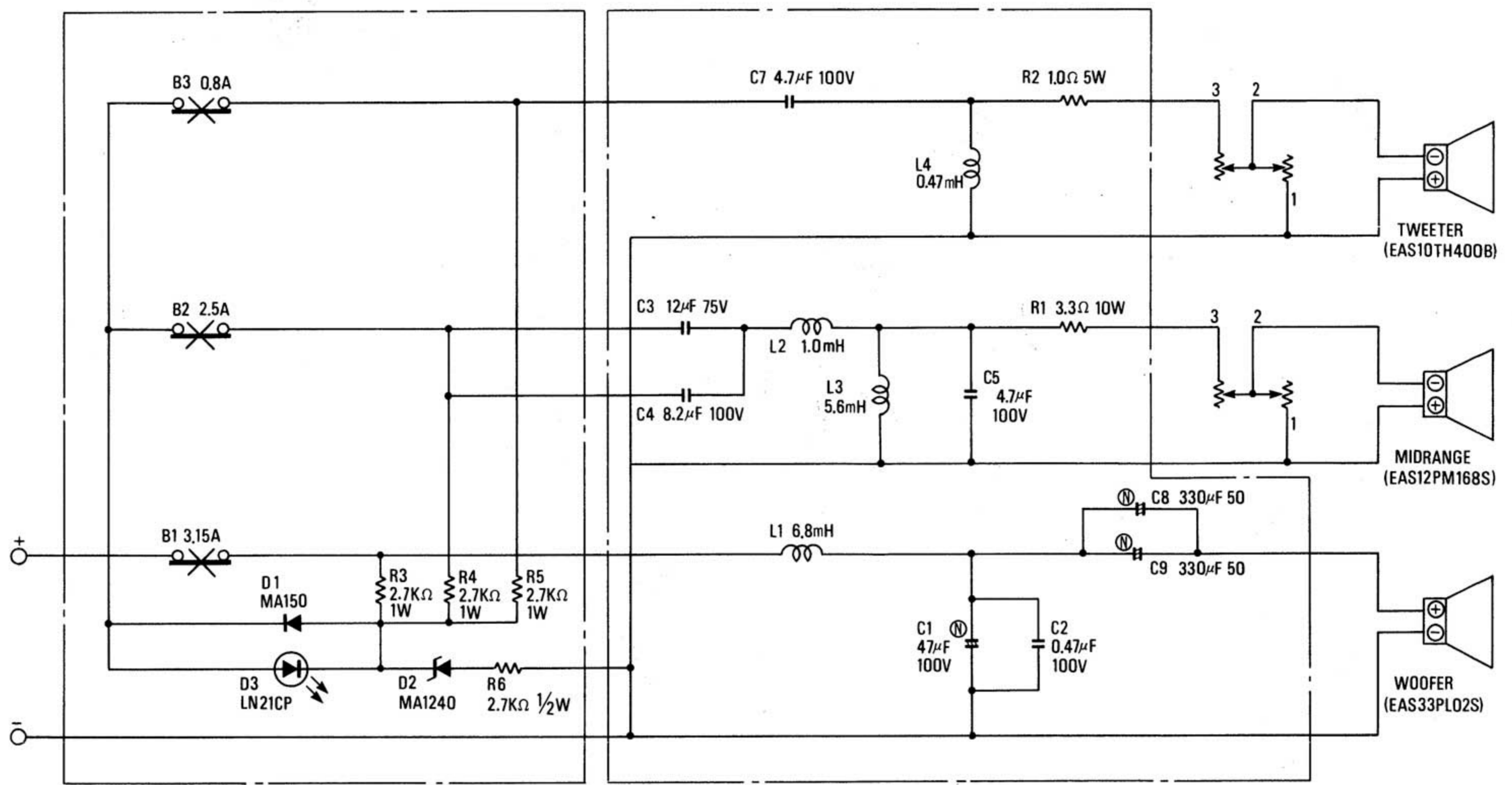

■ CIRCUIT BOARD

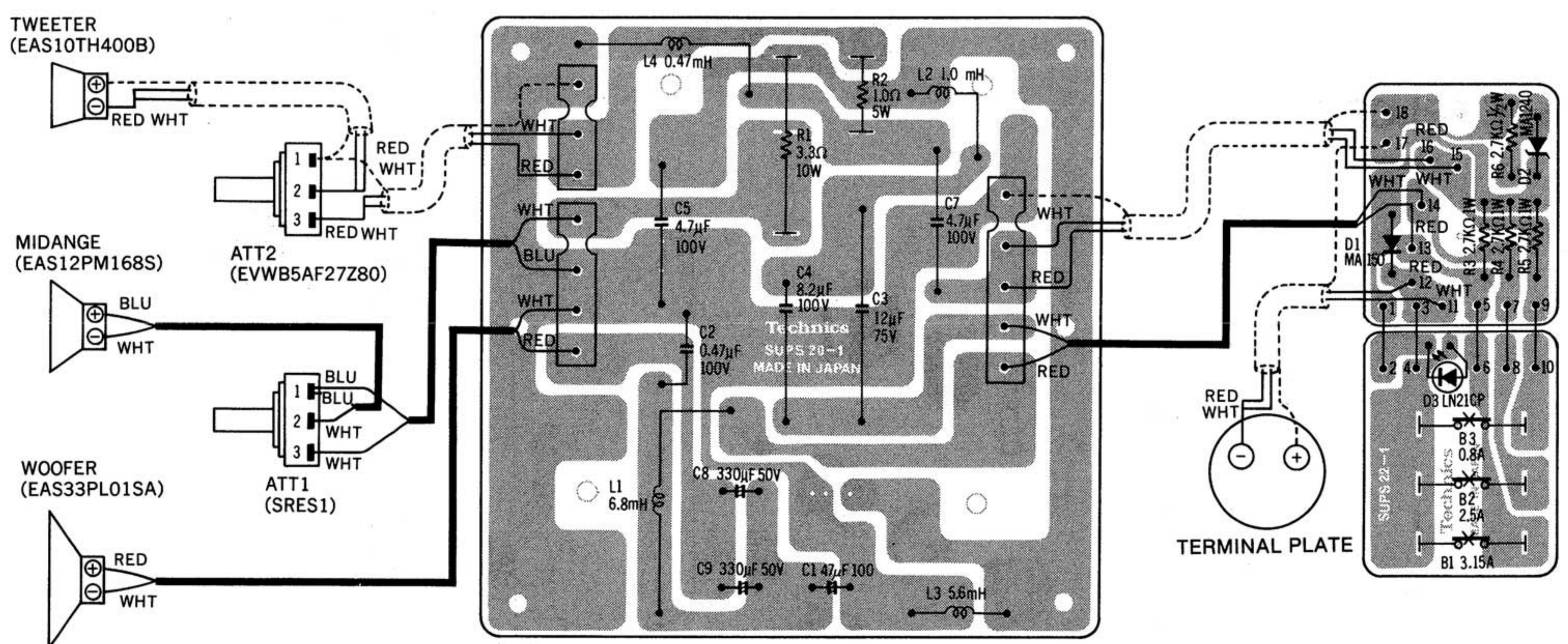

Ref. No.	Part No.
SPEAKERS	
SP1	EAS10TH400B
SP2	EAS12PM168S
SP3	EAS33PL02S
DIODES	
D1	MA162
D2	SVDMZ324
D3	LN21CP
RESISTORS	
R1	ERF10ZK3R3B
R2	ERF5ZK1R0B
R3, 4, 5	ERG1ANJ272
R6	ERD50FJ272

Ref. No.	Part No.
CAPACITORS	
C1	ECEA100Y47
C2	ECQE1474KZ
C3	ECQE07126KZ
C4	ECQE1825KZ
C5, 7	ECQE1475KZ
C8, 9	ECEA50N330M
COILS	
L1	SLCSC682JU
L2	SLCSA102JU
L3	SLCSC562JU
L4	SLCSA471KU

Ref. No.	Part No.
ATTENUATORS	
ATT1	SRES1
ATT2	EVWB5AF27Z80
BREAKERS	
B1	SSB31AB01-1
B2	SSB25AB01-1
B3	SSB08AB01-1

SB-7/K

EXPLODED VIEW

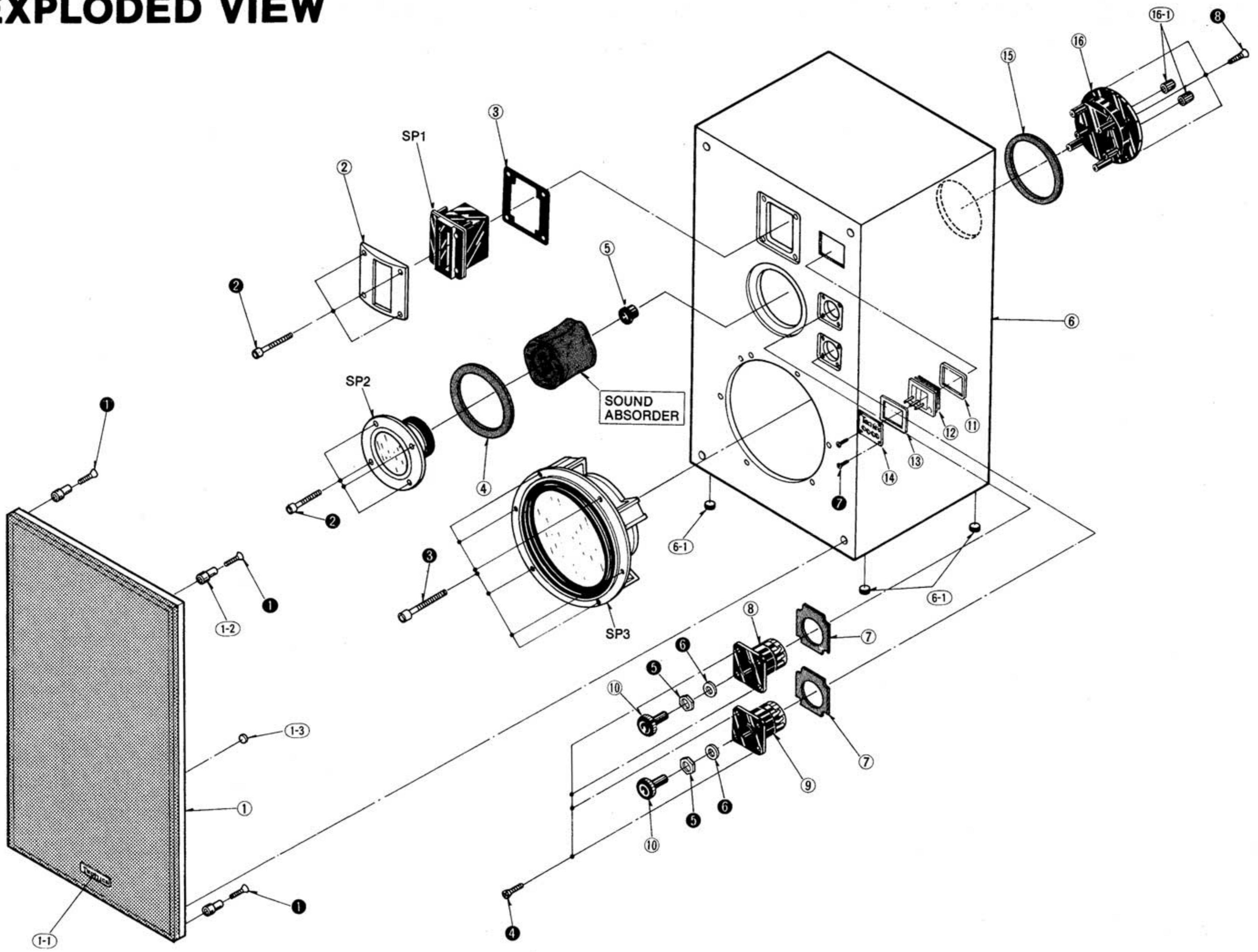

SB-10/K

EXPLODED VIEW

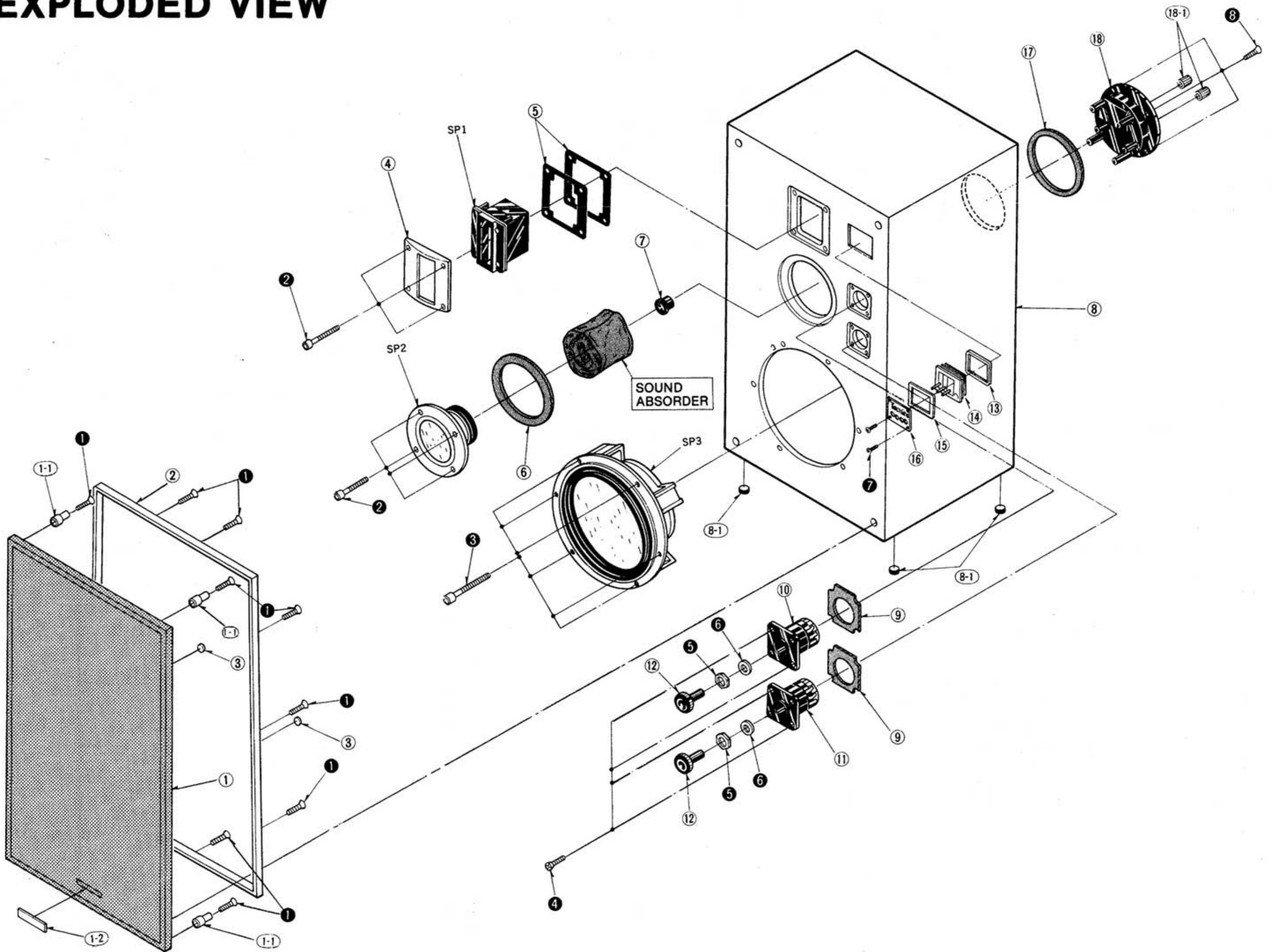

SB-7/K

REPLACEMENT PARTS LIST

- NOTES:** 1. Part numbers are indicated on most mechanical parts.
Please use this part number for parts orders.
2. SB-7K (XA) → [KXA], SB-7 (XG) → [XG], SB-7K (XGB) → [KXGB], SB-7 (XGE) → [XGE], SB-7K (XGF) → [KXGF], SB-7K (XG) → [KXG].

Ref. No.	Part No.	Part Name & Description
CABINET PARTS		
1 [XG, XGE]	SYBS24-2	Grill
1 [except XG, XGE]	SYBS24-1	Grill
1-1	SGB549	Badge, Grill
1-2	SHG1249-2	Net Catch
1-3	SHSS3020	Spacer
2	SGWS2	Panel
3	SHRS9008	Spacer
4	SHRS9010	Spacer
5	SHG1301	Bushing
6 [XG, XGE]	SKAB7F	Cabinet
6 [except XG, XGE]	SKAB7F-1	Cabinet
6-1	SHS2371	Felt Foot
7	SHRS9011	Spacer
8	SGES23-2	Panel Attenuater
9	SGES23-3	Panel Attenuater
10	SBNS3	Knob Attenuater
11	SHRS9019	Spacer
12	SMES2	Bracket
13	SHGS6011	Spacer
14	SGKS34	Panel
15	SHR9389	Spacer
16	SJFS4201-1	Terminal Ass'y
16-1	SNES4001	Knob Speaker Terminal

Ref. No.	Part No.	Part Name & Description
SCREWS and WASHERS		
①	XSS3+8BVS	Screw
②	XVESS4B20FNS	Screw
③	XVESS5B25FNS	Screw
④	XMC31+13FZ	Screw
⑤	XNG9E	Nut
⑥	XWV9	Washer
⑦	XMC27+13FZ	Screw
⑧	XMC31+13FZ	Screw
ACCESSORIES		
A1	SQF53	Instruction Book
A2	SWXS200-1	Cord Speaker
PACKING PARTS		
P1 [XG, XGE]	SPGS35-2	Carton
P1 [KXG, KXGB]	SPGS35-3	Carton
P1 [KXA]	SPGS35-5	Carton
P1 [KXGF]	SPGS35-6	Carton
P2	SPSS6042	Pad Bottom
P3	SPSS1004	Pad Corner
P4	SPSS1004-1	Pad Corner
P5	SPHS6007	Pad Diffuser
P6	SPP503-1	Polyethylene Bag Unit
P7	SPE27	Top

SB-10/K

REPLACEMENT PARTS LIST

- NOTES:** 1. Part numbers are indicated on most mechanical parts.
Please use this part number for parts orders.
2. SB-10K (XA) → [KXA], SB-10K (XG) → [KXG], SB-10K (XGB) → [KXGB], SB-10K (XGE) → [KXGE], SB-10K (XGF) → [KXGF].

Ref. No.	Part No.	Part Name & Description
CABINET PARTS		
1	SYBS25-1	Grill
1-1	SHG1245-2	Net Catch
1-2	SGB549	Badge
2	SGXS6005	Ornament
3	SHSS3021	Spacer
4	SGWS2	Panel
5	SHRS9008	Spacer
6	SHRS9012	Spacer
7	SHG1301	Bushing
8	SKAB10M	Cabinet
8-1	SHS2371	Felt Foot
9	SHRS9011	Spacer
10	SGES23-2	Panel Attenuater
11	SGES23-3	Panel Attenuater
12	SBNS3	Knob Attenuater
13	SHRS9019	Spacer
14	SMES2	Bracket
15	SHGS6011	Spacer
16	SGKS35	Panel
17	SHR9389	Spacer
18	SJFS4202-1	Terminal Ass'y
18-1	SNE4015	Knob Speaker Terminal

Ref. No.	Part No.	Part Name & Description
ACCESSORIES		
A1	SQFS55	Instruction Book
A2	SWXS200-1	Cord Speaker
SCREWS and WASHERS		
①	XMS27+16FZ	Screw
②	XVESS4B30FNS	Screw
③	XVESS6B30FN	Screw
④	XMC31+13FZ	Screw
⑤	XNG9E	Nut
⑥	XWV9	Washer
⑦	XMC27+13FZ	Screw
⑧	XMC31+13FZ	Screw
PACKING PARTS		
P1 [KXG, KXGB, KXGE]	SPGS36-2	Carton
P1 [KXA]	SPGS36-4	Carton
P1 [KXGF]	SPGS36-5	Carton
P2	SPSS6043	Pad Bottom
P3	SPSS6044	Pad Upper
P4	SPS1893	Pad Corner
P5	SPS1893-1	Pad Corner
P6	SPHS6012	Pad Diffuser
P7	SPHS6010	Pad Diffuser
P8	SPP611	Polyethylene Bag Unit

SB-7/K, SB-10/K

● How to Remove Tweeter (SP1)

- Remove 4 setscrews ② with hexagon wrench (4 mm).
- Disconnect two lead wires from speaker terminals.

● How to Remove Midrange (SP2)

- Remove 4 setscrews ② with hexagon wrench (4 mm).
- Disconnect two lead wires from speaker terminals.

● How to Remove Woofer (SP3)

- Remove 4 setscrews ③ with hexagon wrench [SB-7 (5 mm), SB-10 (6 mm)]
- Disconnect two lead wires from speaker terminals.